



## 2.5" SATA SSD 3IE2-P

### HIGHLIGHT FEATURES

- 2.5" SATA III SSD solution for industrial field
- High IOPS
- Intelligent error recovery system
- iSMART disk health monitoring
- iData Guard for abnormal power failure
- PLP (iCell) technology for data protection (optional)
- Supports wide temperature from -40°C to 85°C

### SPECIFICATIONS

<b>Model Name</b>	2.5" SATA SSD 3IE2-P
<b>Flash Type</b>	iSLC (MLC)
<b>Interface</b>	SATA III 6.0 Gb/s
<b>Form Factor</b>	2.5" SSD
<b>Capacity</b>	8GB ~ 512GB
<b>Sequential R / W (MB/sec, max.)</b>	530 / 450
<b>P/E Cycle</b>	20,000
<b>TBW (Max.)</b>	10,000
<b>Storage Temperature</b>	-55°C ~ 95°C
<b>Max. Power Consumption</b>	2.3W
<b>Max. Channels</b>	4
<b>External DRAM Buffer</b>	Y
<b>H/W Write Protect</b>	N
<b>S.M.A.R.T.</b>	Y
<b>AES</b>	Y
<b>TCG Opal</b>	Y
<b>Dimension (W x L x H/mm)</b>	69.85 x 100.0 x 6.9
<b>Vibration</b>	20G@[7 ~ 2000Hz]
<b>Shock</b>	1500G@0.5ms
<b>MTBF</b>	>3 million hours
<b>Warranty</b>	5 Years

# DIAGRAM

## Full PCB

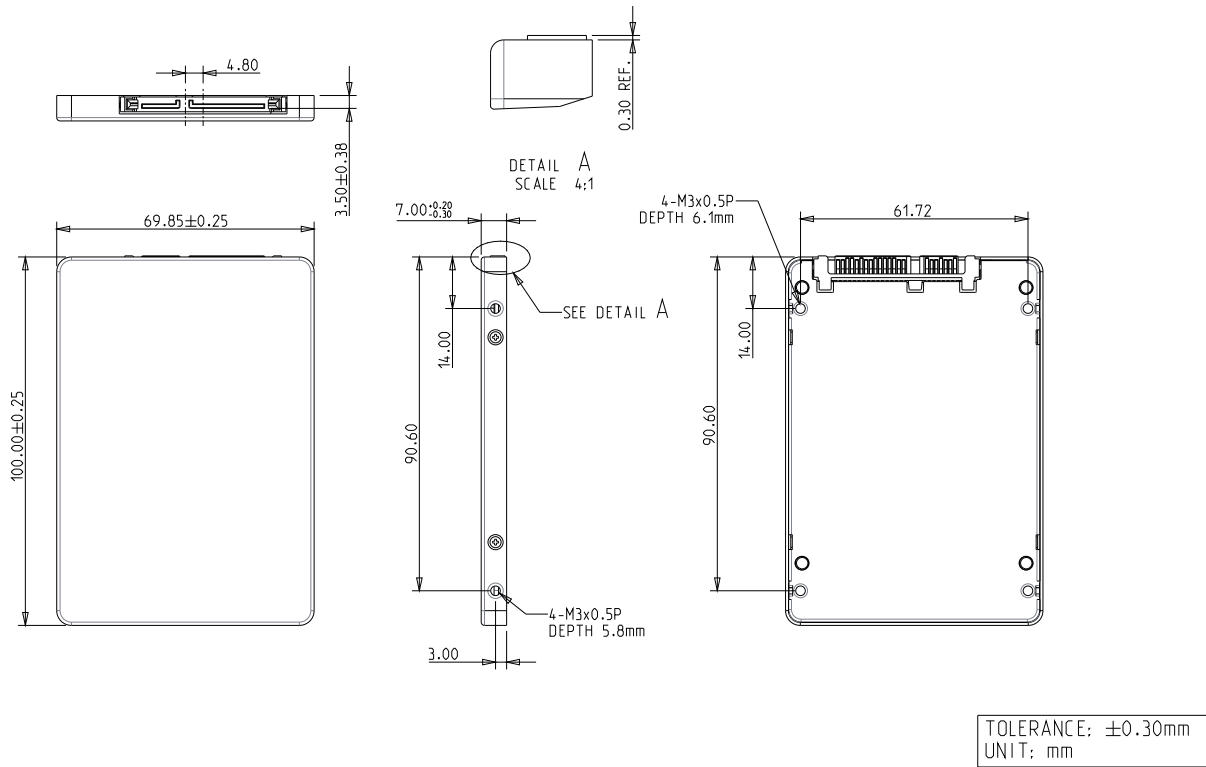

## Slim inside

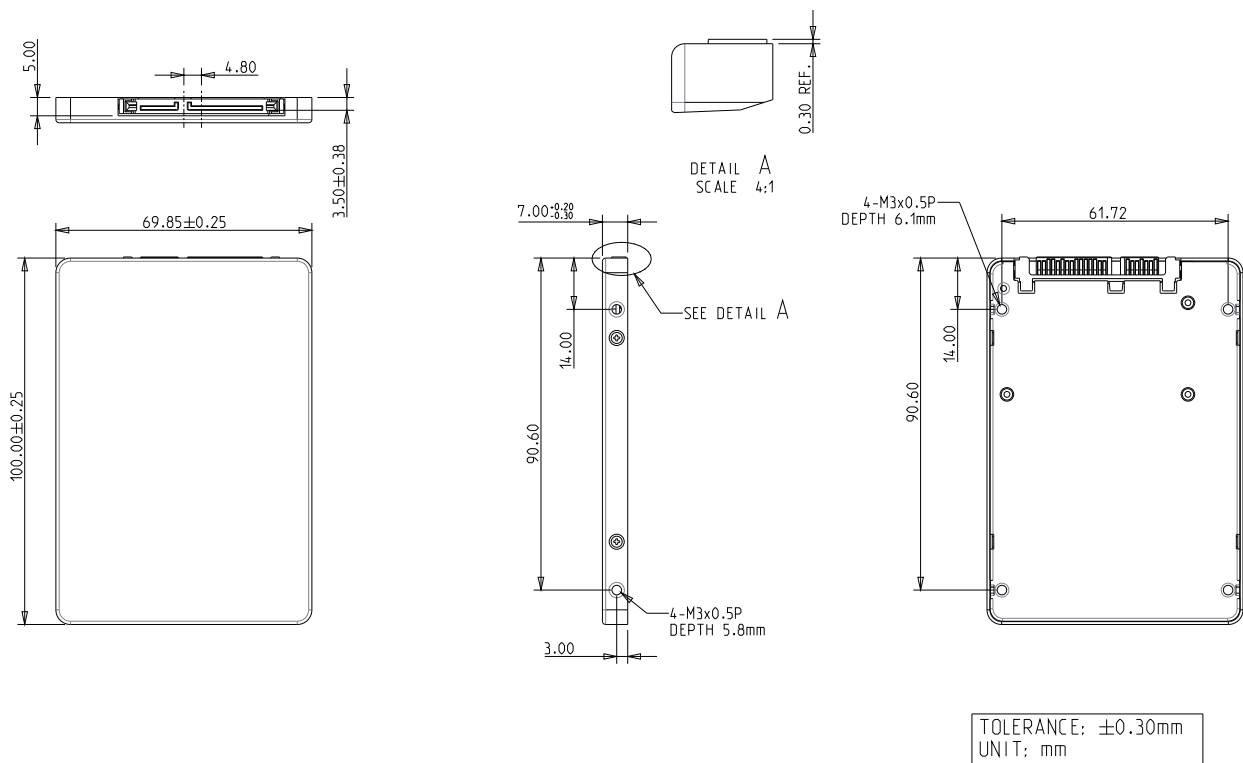

HQ (Taiwan) T +886-2-7703-3000 / E sales@innodisk.com

CN T +86-755-2167-3689 / E sales\_cn@innodisk.com

US T +1-510-770-9421 / E usasales@innodisk.com

EU T +31-40-3045-400 / E eusales@innodisk.com

JP T +81-3-6667-0161 / E jp\_sales@innodisk.com

**innodisk**

**ORDER INFO.**

Operating Temperature	Standard Grade (0°C ~ 70°C)	Industrial Grade (-40°C ~ 85°C)
8GB	DHS25-08GD81BC*DC(P)	DHS25-08GD81BW*DC(P)
16GB	DHS25-16GD81BC*&C(P)	DHS25-16GD81BW*&C(P)
32GB	DHS25-32GD81BC*QC(P)	DHS25-32GD81BW*QC(P)
64GB	DHS25-64GD81BC*QC(P)	DHS25-64GD81BW*QC(P)
128GB	DHS25-A28D81BC*QC(P)	DHS25-A28D81BW*QC(P)
256GB	DHS25-B56D81BC1QC(P)	DHS25-B56D81BW1QC(P)
512GB	DHS25-C12D81BCAQC(P)	DHS25-C12D81BWAQC(P)

\*. PCB version control

&. S : 1 channel / D : 2 channels / Q : 4 channels

(P) : PLP (iCell) (Optional)

For TCG OPAL function, the PN Code 10th ~ 12th will be D82.

**HQ (Taiwan)** T +886-2-7703-3000 / E sales@innodisk.com

**CN** T +86-755-2167-3689 / E sales\_cn@innodisk.com

**US** T +1-510-770-9421 / E usasales@innodisk.com

**EU** T +31-40-3045-400 / E eusales@innodisk.com

**JP** T +81-3-6667-0161 / E jp\_sales@innodisk.com

